

Vibration Analysis ISO 18436-2 Category I-IV

VIBRATION ANALYST TRAINING
& CERTIFICATION



www.mobiusinstitute.com

LEARN THE MOBIUS WAY

WHY LEARN WITH MOBIUS INSTITUTE™?

There are many reasons why over 8,000 students choose Mobius Institute every year, and why you should choose Mobius Institute for your vibration training and certification.

- We make complex topics simple with amazing 3D animations and simulations that make you say, “Ah, now I get it!”
- We give you access to the entire course before the public and virtual live instructor-led class begins so you are better prepared, and then for four months after the course, just in case you still have questions and for a refresher.
- We use anonymous stress-free polling throughout the course to ensure you truly understand each topic, and the instructor knows when to move on to the next topic - no student is left behind.
- Our Vibration Analysis training is ISO/IEC 17024 and ISO 18436-2 accredited and is globally recognized through the Mobius Institute Board of Certification (MIBoC).



www.mobiusinstitute.com

WITH MOBIUS INSTITUTE™, YOU CAN *LEARN YOUR WAY.*

We offer the ultimate flexibility. See the course details for more information.



CLASSROOM INSTRUCTOR-LED COURSES

We have 250+ Training Partners in 175+ countries, offering 26+ languages.



VIRTUAL INSTRUCTOR-LED COURSES

Attend a virtual course - just like a live course, but you learn online.



PRIVATE ON-SITE INSTRUCTOR-LED COURSES

Have the instructor come to your site to save your precious time and money.



ONLINE VIDEO COURSES

Self-paced eLearning courses and iLearnReliability Learning Management System (LMS) courses.

WHY BECOME CERTIFIED BY THE MOBIUS INSTITUTE BOARD OF CERTIFICATION™?

There are so many benefits to becoming certified:

- You should be recognized for your achievements; not everyone is up to the challenge of understanding vibration analysis, let alone successfully collecting data and utilizing it
- Being certified by an accredited certification organization is a major step up from simply passing a test. Yes, the process is more complicated and strict but you will be in an elite group of accredited analysts.
- The educational process is extremely valuable, but being certified tells an employer (or a consulting client) that you are capable of doing an important job

Mobius Institute has certified more vibration analysts than any other organization, and we have only been offering certification since 2005. More than 65,000 vibration analysts around the world, just like you, chose Mobius Institute.

You will receive a digitally encrypted certificate, an ID card and a personalized logo that you should use in email signatures and elsewhere that you want people to know about your achievements.



VCAT-I Vibration Analyst

ISO 18436-2 Category I

Hone your abilities as a skilled vibration technician - capable of collecting quality data, and performing basic analysis and data validation—with advanced 3D animations and interactive simulations that make everything easy to understand.

Welcome to the beginning of your vibration analysis journey. The good news is you are in the right place. Our VCAT-I ISO Category I course will set you up for success.

Once you complete the training, you can take the exam with confidence, and become certified to ISO 18436-2 Category I via the internationally respected Mobius Institute Board of Certification [MIBoC]. MIBoC certification is accredited to ISO/IEC 17024 - there is no higher standard. You will join thousands of other Mobius Institute certified analysts around the world.

VCAT-I CANDIDATE PROFILE

This course is intended for the vibration analyst who will:

- Collect vibration data
- Validate that the data is good
- Begin to perform basic analysis
- Use the training and certification as the start of a new and rewarding career as a vibration analyst

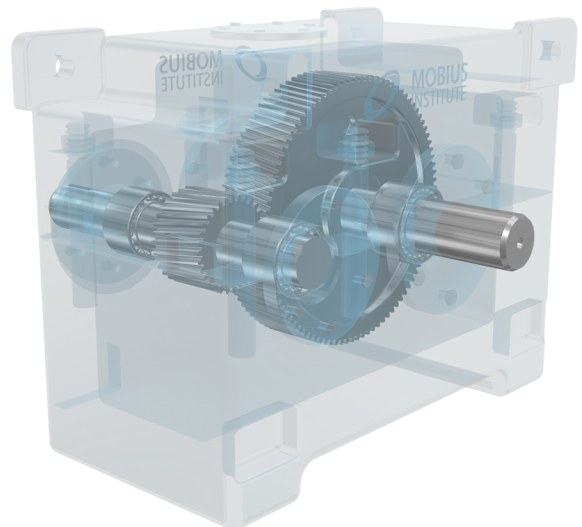

VCAT-I Vibration Analyst ISO 18436-2 Category I

WHAT WILL YOU GAIN FROM TAKING THIS COURSE?

There are so many benefits to taking this course. You will learn...

- About condition monitoring, including a summary of the most common technologies
- About reliability improvement
- How vibration analysis plays a key role in reliability improvement
- How machines work via the supplementary self-study “equipment knowledge” section of the manual
- The fundamentals of vibration: waveforms, spectra, and simple metrics (overall levels, RMS, peak, peak to peak, and crest factor)
- How to take dependable, repeatable, high-quality vibration readings
- About vibration sensors, and how and where to mount them
- The basics of the analysis process, primarily with vibration spectra
- The basics of the key analyzer settings: Fmax, resolution, and averaging
- The basics of setting alarm limits
- The common “failure modes” of machines and how to detect them, including rolling element bearing faults, unbalance, misalignment, looseness, and resonance

VCAT I FAST FACTS

Duration:

30 hours, typically over four days

Format:

- Live public course
- Private on-site course
- Virtual live online course
- Video distance learning online course

Compliance:

- Training: ISO 18436-2
- Certification: ISO 18436-2, ISO/IE 17024

Exam:

- 2 hours
- 60 multiple-choice questions
- 70% passing grade
- Can be taken online or in-person at the course

Certification requirements:

- Training course completed
- 6-months of practical vibration analysis work experience, verified by supervisor/manager
- Pass the exam
- Valid for 5 years

Pre-study:

- Access to the Learning Zone upon registration and payment. For online distance learning, access to the learning platform for four months from registration and payment
- Complete set of videos covering every topic
- An excellent way to be prepared and get the most from the course

Post-study:

- Continue accessing the Learning Zone for 4 months after completing your course. Plus, enjoy the option to upgrade to a 1-year Continued Education plan for extended learning
- Continue learning for free on WWW.MOBIUSCONNECT.COM with online forums, webinars, tutorials, etc.





TOPICS COVERED - CATEGORY I

➤ Maintenance practices

- Reactive, preventive, condition-based, proactive
- How to decide between them

➤ Condition monitoring

- Why it works
- Ultrasound, infrared, oil analysis, wear particle analysis, and electric motor testing

➤ Principals of vibration

- Waveforms
- Metrics: overall levels, RMS, Pk, Pk-to-Pk, and crest factor

➤ Introduction to vibration measurement

- Vibration sensors: displacement, velocity, acceleration
- Vibration units
- Mounting: where and how
- Naming conventions
- Repeatability and quality
- Vibration axes: V, H, A, R and T
- What are “routes” and how do you create them?
- Detecting and avoiding poor data

➤ An introduction to the time waveform

➤ An introduction to the spectrum

- An introduction to forcing frequencies

➤ A brief introduction to phase

➤ Signal processing (just the absolute basics)

- A quick tour of your analyzer settings
- Fmax
- Resolution
- Spectral averaging

➤ Vibration analysis

- The spectrum analysis process

➤ What is resonance - a quick introduction

➤ Diagnosing common fault conditions

- Unbalance
- Misalignment
- Rolling element bearing failure
- Looseness
- Resonance

➤ Setting alarm limits

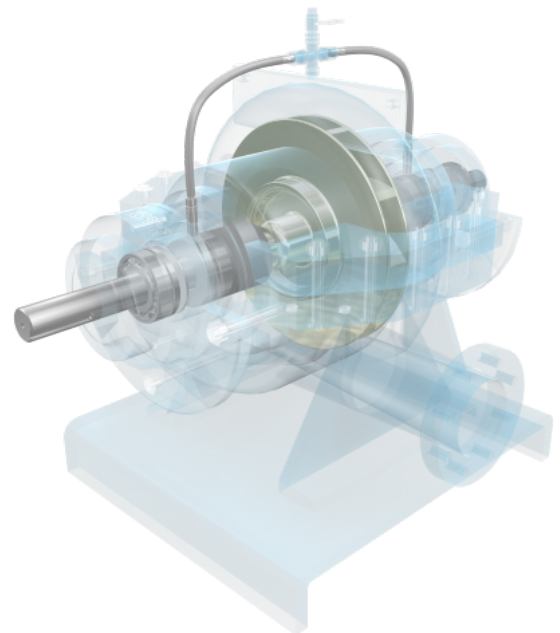

VCAT-II Vibration Analyst

ISO 18436-2 Category II

Cultivate competency as a vibration analyst - capable of diagnosing a wide range of faults, conducting special tests, and performing alignment and balancing - with advanced 3D animations and interactive simulations that make everything easy to understand.

So, you are ready to take the next step in your vibration analysis career. The good news is you are in the right place. Our VCAT-II ISO Category II course teaches you what you need to know to be a successful, confident, and competent vibration analyst.

We will teach you how to diagnose a wide range of fault conditions. We will teach you how to collect the right data with the correct vibration analyzer settings. And we will teach you some useful tips and tricks so that you may validate the diagnoses that you make. In addition, we will teach you about shaft alignment and balancing so that you can improve the reliability of the equipment.

Once you complete the training, you can take the exam with confidence, and become certified to ISO 18436-2 Category II via the internationally respected Mobius Institute Board of Certification [MIBoC]. The MIBoC certification is accredited to ISO/IEC 17024 - there is no higher standard. You will join thousands of other Mobius certified analysts around the world.

VCAT-II CANDIDATE PROFILE

This course is intended for the vibration analyst who will:

- Collect vibration data
- Validate that the data is good
- Set up the analyzer for routine data collection and special tests
- Diagnose most of the common fault conditions
- Perform special tests to validate unbalance, misalignment, resonance, looseness, and other conditions
- Know how to perform precision shaft alignment and balancing
- Use the training and certification as the next step in a rewarding career as a vibration analyst

WHAT WILL YOU GAIN FROM TAKING THIS COURSE?

There is a great deal to learn, but it will help you to perform your role with confidence. In this course you will:

- Increase your knowledge on maintenance practices, condition monitoring, and the common condition monitoring technologies
- Increase your knowledge about data collection, testing techniques, sensor types, and so on
- Learn a great deal about signal processing and the settings of your vibration analyzer
- Increase your knowledge of spectrum analysis, time waveform analysis, and phase analysis
- Understand why phase analysis and time waveform analysis are both critical tools used by the vibration analyst
- Learn common failure modes and how to detect them, including unbalance, misalignment, looseness, resonance, pump/fan/compressor vane, and flow issues, cavitation, turbulence, gearbox failures, rolling element bearing failure, and more
- Learn high-frequency bearing and gear fault detection techniques: demodulation, enveloping, shock pulse, PeakVue, Spike Energy, and others
- Be able to use spectra, phase readings, time waveforms, bump and impact tests, to test for looseness, resonance, and other conditions
- Learn precision shaft alignment and soft foot correction
- Learn single and two-plane balancing
- Learn the basics of setting alarm limits: band alarms, and mask/envelope alarms

The key with the VCAT II course: you will transition from being a person who is primarily capable of collecting data to a person who can diagnose faults on critical machinery, and in some cases, prevent or correct them.

VCAT II FAST FACTS

Duration:

38 hours, typically over five days

Format:

- Live public course
- Private on-site course
- Virtual online course
- Video distance learning online courses

Compliance:

- Training: ISO 18436-2
- Certification: ISO 18436-2, ISO/IE 17024

Exam:

- 3 hours
- 100 multiple-choice questions
- 70% passing grade
- Can be taken online or in-person at the course

Certification requirements:

- Training course completed
- 18-months of practical vibration analysis work experience, verified by supervisor/manager
- Pass the exam
- Valid for 5 years

Pre-study:

- Access to the Learning Zone upon registration and payment. For online distance learning, access to the learning platform four months from registration and payment
- Complete set of videos covering every topic
- An excellent way to be prepared and get the most from the course

Post-study:

- Continue accessing the Learning Zone for 4 months after completing your course. Plus, enjoy the option to upgrade to a 1-year Continued Education plan for extended learning
- Continue learning for free on WWW.MOBIUSCONNECT.COM with online forums, webinars, tutorials, etc.





TOPICS COVERED - CATEGORY II

➤ Review of maintenance practices

➤ Review of condition monitoring technologies

➤ Principals of vibration

- Complete review of basics
- Waveform, spectrum (FFT), phase and orbits
- Understanding signals: modulation, beating, sum/difference

➤ Data acquisition

- Transducer types: Non-contact displacement Proximity probes, velocity sensors, and accelerometers
- Transducer selection
- Transducer mounting and natural frequency
- Measurement point selection
- Following routes, and test planning
- Common measurement errors

Signal processing

- • Filters: Low pass, band pass, high pass, band stop
- Sampling, aliasing, dynamic range
- Resolution, Fmax, data collection time
- Averaging: linear, overlap, peak hold, time synchronous
- Windowing and leakage

Vibration analysis

- • Spectrum analysis
- Time waveform analysis (introduction)
- Orbit analysis (introduction)
- Phase analysis: bubble diagrams and ODS
- Enveloping (demodulation), shock pulse, spike energy, PeakVue

➤ Fault analysis

- Natural frequencies and resonances
- Unbalance, eccentricity and bent shaft
- Misalignment, cocked bearing and soft foot
- Mechanical looseness
- Rolling element bearing analysis
- Analysis of induction motors
- Analysis of gears
- Analysis of belt-driven machines
- Analysis of pumps, compressors, and fans

➤ Equipment testing and diagnostics

- Impact testing and bump tests
- Phase analysis

➤ Corrective action

- General maintenance repair activities
- Review of balancing process
- Review of shaft alignment

➤ Setting alarm limits

- Setting baselines
- Setting alarms: band, envelope/mask, statistical

➤ Acceptance testing

➤ Review of relevant ISO standards



VCAT-III Vibration Analyst

ISO 18436-2 Category III

Acquire the expertise to become a vibration leader and master analyst - capable of managing the condition monitoring program, diagnosing the widest range of fault conditions, verifying and correcting resonance problems, performing complex balancing machinery - with advanced 3D animations and interactive simulations that make everything easy to understand.

If you are ready to be the senior vibration analyst, with the capability of handling all the common fault conditions and leading the Category I and II analysts, then this is the course for you.

The Category III course is intended for people who are confident with spectrum analysis but who wish to push on and learn more about signal processing, time waveform and phase analysis, cross-channel testing, machine dynamics, and fault correction. If you wish to truly advance in vibration analysis and be able to run a successful condition monitoring team, then you are ready for this course.

- You will learn to diagnose all of the common fault conditions with rolling element and sleeve bearing machines, utilizing spectra, high-frequency detection techniques, time waveforms, phase readings, and other techniques.
- You will also learn machine dynamics (natural frequencies, resonance, etc.), how to perform resonance testing, and how to correct resonance problems. The course also covers the single and cross-channel measurement capabilities of your analyzer.
- And after completing the CAT-III course, you will be able to set up and run a successful vibration program and mentor the junior analysts.

Once you complete the training, you can take the exam with confidence, and become certified to ISO 18436-2 Category III via the internationally respected Mobius Institute Board of Certification [MIBoC]. The MIBoC certification is accredited to ISO/IEC 17024 - there is no higher standard. You will join thousands of other Mobius certified analysts around the world.

VCAT-III CANDIDATE PROFILE

This course is intended for the vibration analyst who will:

- Have a minimum of 3 years of experience
- Have a senior role in the condition monitoring team
- Have others report to them to verify diagnoses
- Be responsible for the most complex fault conditions (with the possible exception of sleeve bearing, flexible rotor machines)
- Need to perform complex tests to validate fault conditions (e.g., resonance) and find a solution
- Want to be a leader of the vibration team or take a leading role in diagnosing faults and making repair recommendations
- Want to understand all data collector options, special test capabilities, all analysis tools and understand the widest range of fault conditions
- Seek to become certified to international standards (ISO-18436) by an accredited certification body
- Want to understand all condition monitoring technologies, how and when to apply them
- Want to understand machine dynamics (natural frequencies, resonance, ODS), how to perform resonance testing and how to correct resonance problems
- Use the training and certification as the next step in a rewarding career as a vibration analyst

WHAT WILL YOU GAIN FROM TAKING THIS COURSE?

There is a great deal to learn, but it will help you to perform your role with confidence. The topics covered in this course include:

- Review of condition monitoring technologies
- Signal processing and data acquisition
- Time waveform analysis
- Phase analysis
- Dynamics (natural frequencies and resonance)
- Testing for natural frequencies
- Operating Deflection Shape (ODS) analysis
- Modal analysis and introduction to FEA
- Correcting resonances
- Rolling element bearing fault detection
- Journal bearing fault detection
- Electric motor testing
- Pumps, fans, and compressors
- Gearbox fault detection
- Corrective action
- Acceptance testing

The key is that with the VCAT-III course, you will transition from being a vibration analyst who should be supervised to a person who is capable of running the program, being a senior consultant, solving difficult problems, and taking a leadership role.

VCAT III FAST FACTS

Duration:

38 hours, typically over five days

Format:

- Live public course
- Private on-site course
- Virtual online course
- Video distance learning online courses

Compliance:

- Training: ISO 18436-2
- Certification: ISO 18436-2, ISO/IE 17024

Exam:

- 4 hours
- 100 multiple-choice questions
- 70% passing grade
- Can be taken online or in-person at the course

Certification requirements:

- Training course completed
- 36-months of practical vibration analysis work experience, verified by supervisor/manager
- Have previously been certified to VCAT-II by a MIBoC-approved certification body
- Pass the exam
- Valid for 5 years

Pre-study:

- Access to the “Learning Zone” upon registration and payment
- Complete set of videos covering every topic
- An excellent way to be prepared and get the most from the course

Post-study:

- Continue accessing the Learning Zone for 4 months after completing your course. Plus, enjoy the option to upgrade to a 1-year Continued Education plan for extended learning
- Continue learning for free on WWW.MOBIUSCONNECT.COM with online forums, webinars, tutorials, etc.





TOPICS COVERED - CATEGORY III

➤ Signal processing

- Filters: Low pass, band pass, high pass, band stop
- Sampling, aliasing, dynamic range
- Signal-to-noise ration
- Resolution, Fmax, data collection time
- Averaging: linear, overlap, peak hold, time synchronous
- Windowing and leakage
- Order tracking
- Cross-channel measurements
- Correlation and coherence

➤ Time waveform analysis

- Collecting data - ensuring you have the correct setup
- When should you use time waveform analysis?
- Diagnosing unbalance, misalignment, bent shaft, eccentricity, cocked bearing, resonance, looseness, and other conditions

➤ Phase analysis

- Collecting data
- Bubble diagrams
- Diagnosing unbalance, misalignment, bent shaft, eccentricity, cocked bearing, resonance, looseness, and other conditions

➤ Dynamics (natural frequencies and resonance)

- Natural frequencies and resonances
- Mass, stiffness, and damping
- SDOF and MDOF

➤ Testing for natural frequencies

- Run-up coast down tests
- Bode plots and Nyquist (polar) plots
- Impact and bump tests

➤ Operating Deflection Shape (ODS) analysis

- Can we prove the existence of a natural frequency?
- Visualizing vibration
- Setting up the job
- Collecting phase readings correctly
- Interpreting the deflection shape
- Using Motion Amplification

➤ Modal analysis and intro to FEA

- How does modal analysis differ from ODS?
- How does Finite Element Analysis (FEA) differ from modal analysis
- A quick review of the modal testing process

➤ Correcting resonances

- The effect of mass and stiffness
- Beware of nodal points
- Adding damping
- A “trial and error” approach
- A “scientific” approach
- Isolation
- Tuned absorbers and tuned mass dampers

Continued on page 13...



TOPICS COVERED - CATEGORY III

(continued)

➤ Rolling element bearing fault detection

- Why do bearings fail?
- Cocked bearing, sliding on the shaft or inside the housing, looseness
- EDM and DC motors and VFDs
- Bearing frequencies and what to do when you don't have all the details
- The four stages of bearing degradation
- Ultrasound
- High-frequency detection techniques
- Shock Pulse, Spike Energy, Peak view, and other techniques
- Demodulation/enveloping
- Selecting the correct filter settings
- Spectrum analysis
- Time waveform analysis
- Low-speed bearings

➤ Journal bearing fault detection

- What are journal bearings?
- Measuring displacement
- Introduction to orbit plots
- Using your analyzer to acquire orbit plots
- Introduction to centerline diagrams
- Eccentricity ratio
- Glitch removal
- How the orbit changes with pre-load, unbalance, misalignment, instabilities, oil whirl and whip

➤ Electric motor testing

- How do motors work?
- Diagnosing a range of fault conditions: eccentric rotor, eccentric stator, soft foot, phasing, broken rotor bars, rotor bar, and stator slot pass frequencies
- Motor current analysis

➤ Pumps, fans, and compressors

- Unique fault conditions
- Flow turbulence, recirculation, cavitation

➤ Gearbox fault detection

- Spectrum analysis versus time waveform analysis
- Wear particle analysis
- Gearmesh, gear assembly phase frequency (and common factors)
- Tooth load, broken teeth, gear eccentricity and misalignment, backlash and more

➤ Corrective action

- General maintenance repair activities
- Review of the balancing process and ISO balance grades
- Review of shaft alignment procedures

➤ Running a successful condition monitoring program

- Defining the program
- Setting baselines
- Setting alarms: band, envelope/mask, statistical
- Setting goals and expectations (avoiding common problems)
- Report generation
- Reporting success stories

➤ Review of relevant ISO standards

VCAT-IV Vibration Analyst

ISO 18436-2 Category IV

Achieve the highest status as a vibration analysis professional - capable of handling any condition that may be presented, capable of performing any test, fully understanding flexible rotor machinery - with advanced 3D animations and interactive simulations that make everything easy to understand.

Congratulations on being ready to tackle the Mount Everest of vibration analysis. The good news is you are in the right place. We have developed an amazing set of 3D animations and simulations that even make the Category IV topics relatively easy to understand. Topics that were once only suitable for Ph.D's and math geniuses are now accessible to practical vibration analysts—*as it should be*.

There is a lot to learn. You are required to take 64 hours of training according to ISO 18436-2, but we provide over 80 hours with combined online distance learning and a 5-day in-person instructor led course.

After you take the online course, you must then attend the face-to-face course where the instructor will review the topics and take you through a series of “worked examples”.

This training process will ensure you understand the topics so that you can apply the techniques in your role as an expert vibration analyst.

This training process will also help you achieve the pinnacle of the vibration world - the ISO Category IV Vibration Analyst.

Two Part Training Course

The topics are roughly broken into two parts.

Part 1 consists of:

Over 52 hours of online movies, demonstrations, and exercises.
Extend your Category III knowledge in signal processing, time waveform analysis, system dynamics and more.

Go deep into rotor and bearing dynamics, and rotor balancing.
Practice questions with detailed answers.

Part 2 consists of:

5-day in-person classroom course.
Reinforce the topics from part 1.
Complete and discuss the practice questions you began in part 1 to confirm your knowledge.
Optional certification exam.

Mobius Institute™ animations and simulations to the rescue

Category IV does cover a lot of practical content, but there is a good dose of theory as well. It is the theory and the calculations that can intimidate many vibration analysts. But we have done our best to make it all understandable and achievable. We provide you with a long list of worked examples with clear explanations on how to perform the calculations. But we also have animations and simulations that let you understand exactly what is going on. Rather than abstract concepts that only Ph.D's feel comfortable with, you will be able to connect theory with reality because you will see it right there on the screen.

Once you complete the training, you can take the exam with confidence, and become certified to ISO 18436-2 Category IV via the internationally respected Mobius Institute Board of Certification [MIBoC]. The MIBoC certification is accredited to ISO/IEC 17024 - there is no higher standard. You will join thousands of other Mobius certified analysts around the world.

VCAT-IV CANDIDATE PROFILE

This course is intended for the vibration analyst who will:

- Have a minimum of 5 years of experience
- Have a senior role in the condition monitoring team, but you want to go beyond and truly reach the peak of the vibration world
- Be able to understand the measurements associated with critical turbomachinery and other fluid-film bearing machines
- Be able to do everything the Category III can do – only better!

WHAT WILL YOU GAIN FROM TAKING THIS COURSE?

There is a great deal to learn, but it will help you to perform your role with confidence. The topics covered in this course include:

- Advanced signal processing
- Cross channel measurements
- Dynamics (mass/stiffness/damping, natural frequencies, modes)
- Resonance testing (run-up/coast down tests, impact tests, ODS, modal analysis)
- Corrective action (flow control, resonance correction, isolation, and damping)
- Proximity probe and casing measurements
- Orbit and centerline plot analysis
- Rotor dynamics (natural frequencies, modeling)
- Journal bearings (design, fluid film instabilities)
- Flexible rotor balancing
- Torsional vibration

The key is that with the VCAT-IV course, you will transition from being a very good vibration analyst to a vibration super-hero!

VCAT IV FAST FACTS

Duration:

64 hours total:

Part 1: Online Distance Learning. You will have access to online course videos and study materials

Part 2: 5-day in-person course with optional exam

Compliance:

- Training: ISO 18436-2
- Certification: ISO 18436-2, ISO/IEC 17024

Exam:

- 5 hours
- 60 multiple-choice questions, with calculations required
- 70% passing grade
- Can be taken online or in-person at the course

Certification requirements:

- Training course completed
- 60 months of practical vibration analysis work experience, verified by supervisor/manager.
- Have previously been certified to VCAT-III by a MIBoC approved certification body
- Pass the exam
- Valid for 5 years

Post-study:

- Continue accessing the Learning Zone for 4 months after completing your course. Plus, enjoy the option to upgrade to a 1-Year Continued Education





TOPICS COVERED - CATEGORY IV

➤ Principles of vibration

- Vectors, modulation
- Phase
- Natural frequency, resonance, critical speeds
- Force, response, damping, stiffness
- Instabilities, non-linear systems
- Torsional vibration
- Instrumentation
- Proximity probe operation, conventions, glitch removal
- Shaft and casing measurements

➤ Signal processing

- RMS/peak detection
- Analog/digital conversion
- Analog sampling, digital sampling
- FFT computation
- Filters: low pass, high pass, band pass, tracking
- Anti-aliasing
- Bandwidth, resolution
- Noise reduction
- Averaging: linear, synchronous time, exponential
- Dynamic range
- Signal-to-noise ratio
- Spectral maps

➤ Fault analysis

- Spectrum analysis, harmonics, sidebands
- Time waveform analysis
- Orbit analysis
- Shaft centerline analysis
- Transient analysis
- Unbalance, bent shaft, cracked shaft, eccentricity, rubs, instabilities

➤ Fault analysis (continued)

- Resonance and critical speeds
- Turbomachinery

➤ Phase analysis

- Transient analysis
- Enveloping
- Electric motor defects
- Flow-induced vibration, aerodynamics, and liquids
- General fault recognition

➤ Rotor/bearing dynamics

- Rotor/bearing dynamics
- Rotor characteristics
- Rotor modeling (rotor, wheels, bearings, aerodynamic effects)
- Bearing characteristics (fluid film bearings, housing, and supports, seals, couplings)

➤ Corrective action

- Flow control
- Isolation and damping
- Resonance control
- Low and high-speed shop balancing
- Field balancing (single plane, two plane, static/couple, flexible rotor)

Continued on page 17...





TOPICS COVERED - CATEGORY IV

(continued)

➤ Equipment testing and diagnostics

- Impact testing
- Forced response testing
- Transient analysis
- Transfer functions
- Damping evaluation
- Cross channel phase, coherence
- Operating deflection shapes
- Modal analysis

➤ Fault severity determination

- Spectrum analysis
- Time waveform analysis, orbit analysis
- Severity charts, graphs and formula

➤ Reference standards

- ISO
- IEC
- Relevant national standards

GET VIBRATION TRAINED AND CERTIFIED

Learn to be an effective vibration technician - capable of collecting quality data, and performing basic analysis and data validation - with advanced 3D animations and interactive simulations that make everything easy to understand.



SCAN
TO FIND
TRAINING



www.mobiusinstitute.com





➤ WILL I RECEIVE PRE-COURSE STUDY MATERIALS FOR PUBLIC AND LIVE INSTRUCTOR-LED TRAINING?

As a registered student you will receive an instructional email to finalize your course registration. You will also receive a link to our TMS (Training Management System) to monitor your training progress. For all courses except for distance learning and VCAT-IV, you will have access to your personal Learning Zone. Here you will be provided with a digital version of the course materials and the actual course videos containing the same content that will be used when you attend the in-person or virtual live instructor-led class. The Learning Zone may be used for pre-course study, review during the course week, and reference after the course. The access is activated at the time you are registered for the course and expires 4 months after the last day of the course.

For public course you will receive the hard copy manual, activity book, and quick reference guide on the first day of the training. These are required to attend the course.

➤ WILL I RECEIVE STUDY MATERIALS FOR ONLINE DISTANCE LEARNING?

As a registered student you will receive an instructional email to finalize the course registration. You will receive a link to your online learning which is on a separate learning platform from the TMS (Training Management System). You will be enrolled in the online training within 48 hrs of registering. You will have access for 4 months with the option to upgrade to 1-Year Continued Education.

Your purchase includes printed materials, which are the manual, the activity book, and the quick reference guide. You will only be responsible for paying an additional fee for shipping depending on your location. We do not offer the PDF option.

➤ DO YOU OFFER EXTENDED LEARNING ACCESS?

Enhance your learning experience with our 1-Year Continued Education upgrade, extending access to course content, videos, and resources for an entire year beyond the standard 4 months. Stay current, refresh your knowledge, and maintain your edge in the industry. With the option to renew annually, you can continue to review and expand your skills, ensuring ongoing growth and expertise.

➤ DO YOU OFFER ONSITE INSTRUCTOR LED COURSES?

Yes, we can provide training on-site at your facility or any other training facility of your choice with one of our expert instructors. If you are in North America, Australia, or New Zealand please email learn@mobiusinstitute.com for a quotation.

Outside of these areas, contact your local training partner at www.mobiusinstitute.com/training-partners.

➤ MAY I TAKE ONE OF YOUR COURSES IF I AM NOT INTERESTED IN BECOMING CERTIFIED OR IF I HAVE INSUFFICIENT EXPERIENCE FOR CERTIFICATION?

Yes, our courses are open to the public, regardless of experience. If you are involved in vibration analysis or rotating machinery in any capacity, such as sales, marketing, engineering, design, or reliability, you will come away with a far better understanding of how machines are monitored, how faults develop, and what can be done to determine what faults actually exist in a machine. All attendees receive a certificate of completion. Candidates without sufficient experience will still receive a certificate if they pass the exam, but it will note that their experience was insufficient for ISO certification at the time.

➤ AFTER I ATTEND YOUR COURSE AND TAKE THE EXAM, WHEN WILL I RECEIVE NOTIFICATION AS TO WHETHER I PASSED, AND WHEN WILL I RECEIVE MY CERTIFICATE?

You will receive notification of your results 5-10 days after the exam has been received at our Australian office. If you have passed the exam and met all certification requirements, you will receive your Digital Certificate 10-15 days after your exam results notification email.





➤ **HOW LONG IS THE CERTIFICATION VALID?**

Vibration analysis certification is valid for five (5) years.

➤ **WHAT ARE THE EXPERIENCE REQUIREMENTS FOR VCAT I?**

You must have 6 months of practical work experience in the field of machinery condition monitoring and diagnostics. You will be asked to provide the contact details of a manager/supervisor who can verify the work experience details submitted.

➤ **WHAT ARE THE EXPERIENCE REQUIREMENTS FOR VCAT II?**

You must have 18 months of practical work experience in the field of machinery condition monitoring and diagnostics. You will be asked to provide the contact details of a manager/supervisor who can verify the work experience details submitted.

➤ **WHAT ARE THE EXPERIENCE REQUIREMENTS FOR VCAT III?**

You must have 36 months of practical work experience in the field of machinery condition monitoring and diagnostics. You will be asked to provide the contact details of a manager/supervisor who can verify the work experience details submitted. Certification to VCAT III also requires previous VCAT II from a MIBoC approved certification body.

➤ **WHAT ARE THE EXPERIENCE REQUIREMENTS FOR VCAT IV?**

You must have 60 months of practical work experience in the field of machinery condition monitoring and diagnostics. You will be asked to provide the contact details of a manager/supervisor who can verify the work experience details submitted. Certification to VCAT IV also requires previous VCAT III from a MIBoC approved certification body.

➤ **HOW DO I QUALIFY FOR RENEWAL?**

Once you have purchased your certification renewal, the Renewals Team will be advised of your payment. You will then receive an email of any outstanding requirements needed to proceed with your application. You can assist us in this process by logging into your TMS student account to ensure your profile details are current by completing the following:

- Enter a new work experience record to cover the past 5 years of vibration analysis since your certification was issued. (Your experience is required to be verified by your current and/or previous managers)
- Agree to the MIBoC Code of Ethics Document if required
- Agree to the MIBoC Renewal Declaration

➤ **HOW DO I RENEW MY CERTIFICATION?**

You will purchase your certification renewal and the Renewals Team will be advised of your payment. You will then receive an email of any outstanding information required within the Training Management System (TMS) to proceed with your application.





Mobius Institute Board of Certification is an accredited certification body per ISO/IEC 17024 and ISO 18436-1 authorized to provide certification in accordance with ISO 18436-1 and 18436-2.

Mobius Institute Board of Certification (MIBoC) is an impartial and independent entity that is directed by scheme and technical committees to ensure that its certification meets or exceeds the requirements defined by the applicable International Organization for Standardization, ISO 18436 standards.



MOBIUS INSTITUTE is a worldwide provider of reliability improvement, condition monitoring and precision maintenance education to industrial plant managers, reliability engineers, and condition monitoring technicians. Our programs will allow plants to be successful in implementing reliability improvement programs through delivery of more easily understandable and comprehensive training of reliability and vibration analysis via public, in-plant and online education programs.

For more information about additional training courses, software tools, industry terminology and definitions, accredited certification, and specific course details, visit the Mobius Institute website.

© Copyright 2025. Mobius Institute

www.mobiusinstitute.com

Global: +1 (239) 600 - 6828

learn@mobiusinstitute.com

Join thousands of other industry professionals by creating your free custom profile today at WWW.MOBIUSCONNECT.COM

DOWNLOAD THE MOBILE APP  



MOBIUS CONNECT is your gateway to reliability and CBM videos, webinars, articles, tips, and a live feed and forum. You will connect with people, just like you, all over the world.

At MOBIUS CONNECT, you can solve problems, continue learning, and share your experience - all for free!

You must never stop learning.

